

56

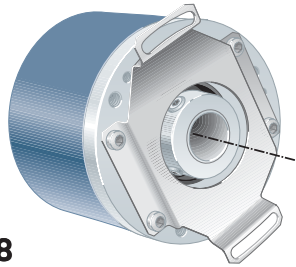

58

Short description:

- >> 13 bit CANopen output
- >> IP 67 at housing, IP 66 at shaft inlet
- >> 9...36 Vdc
- >> Robust housing for harsh environment
- >> Shock and vibration protected

Suitable applications:

- >> Standard to demanding industrial applications
- >> Positioning applications
- >> Printing machines
- >> Packaging machines

General information

Encoder data	
Type	RHA 507
Operating temperature	-40°C .. +80°C
Storage temperature	-30°C .. +80°C
Ingress protection class	IP-67 according to IEC 60529
At shaft inlet	IP-66 according to IEC 60529
Vibration (55 to 2000Hz)	< 300 m/s ² according to IEC 60068-2-6 ⁽¹⁾
Shock (6ms)	< 2000 m/s ² according to IEC 60068-2-27
Cover material	Aluminium
Cover surface treatment	Coated and cromated or anodized
Weight	Approx. 300g
Accuracy and resolution	
Resolution	13 Bit, 8192 positions per revolution
Accuracy	± 1 LSB

Flange option

Flange type	56, hollow-shaft	58, hollow-shaft
Type	Standard	Standard
Diameter	ø58mm	ø58mm
Flange material	Aluminium	Aluminium
Surface treatment	Anodized	Anodized
Torque support	Torque arm	Stator coupling

Shaft option

Hollow-shaft type	Ø 8 mm	Ø 10 mm	Ø 12 mm	Ø 14 mm
Axial shaft load	10 N	10 N	10 N	10 N
Radial shaft load	20 N	20 N	20 N	20 N
Mech. permissible speed	6000 rpm (12 000)	6000 rpm (12 000)	6000 rpm (12 000)	6000 rpm (12 000)
Shaft material	Stainless steel	Stainless steel	Stainless steel	Stainless steel
Moment of inertia	1,9 x 10 ⁻⁶ kgm ²	1,9 x 10 ⁻⁶ kgm ²	2,0 x 10 ⁻⁶ kgm ²	2,0 x 10 ⁻⁶ kgm ²

⁽¹⁾<150m/s² on encoders with connectors

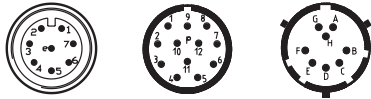

Connection option

Connector type	Cable	8 pin M12	12 pin EML	8 pin PT
Function	Colour	PIN	PIN	PIN
Address Bit 0	White	1	1	A
Address Bit 1	Brown	2	2	B
Address Bit 2	Grey	3	3	C
Address Bit 3	Pink	4	4	D
Address 0V	Blue/Red	NA	11	NA
CAN_H	Green	5	8	G
CAN_L	Yellow	6	9	H
0V	Blue	7	10	F
+EV	Red	8	12	E
Housing	Shield	Chassis	Chassis	Chassis
Connecting direction				
Axial	Yes	Yes	Yes	Yes
Radial	Yes	Yes	Yes	Yes

NA=Not available

Electrical option

Power supply	9-36Vdc
Polarity protected	Yes
Output interface	CANopen
Short circuit protected	Yes
Current consumption	100mA @ 24Vdc
Max current consumpt.	150mA
Physical interface	CAN according to ISO-11898
Supported profile	Device profile for encoders DSP-406
Baud rate ⁽¹⁾	Max. 1Mbit/s software adjustable
Node address	Hardware or software adjustable
Code type	Binary
Supported functions	Code sequence, Preset, Velocity, Scaling, Acceleration, PDO mapping, Heartbeat and Node Guarding
Position update freq.	1kHz
Start up delay	700ms

⁽¹⁾ Default baudrate 125 kBit/s

Accessories

Accessories	Part number	
Configuration file EDS file	619208-01	
Mating connector	8 pin M12	00201081 ⁽¹⁾
	8 pin PT	00201009 ⁽¹⁾
	12 pin EML	01209090 ⁽¹⁾
Torque support	M6	01209143 ⁽²⁾
Torque arm	M6	01208014 ⁽³⁾

⁽¹⁾ Also available with assembled cable.

⁽²⁾ Only for 56 flange.

⁽³⁾ Length 70-1000mm available, specify when ordering.

For additional accessories like assembled cables and torque arms please advise separate datasheets for accessories.

507 — Ruggedized Hollow shaft encoder, Absolute

CANopen



Dimensions

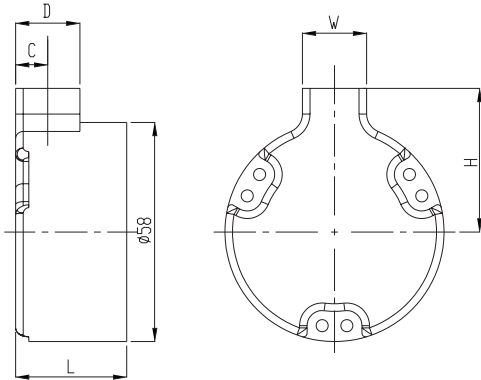

Connector	Orientation	L	H	W	D	C
Cable	Radial	29,4	34	17	17	8,5
	Axial	38,9				
EML	Radial	29,4	32	27	27	13,5
	Axial	38,9				
8p M12	Radial	29,4	38	27	27	9,5
	Axial	38,9				
8p PT	Radial	29,4	41	27	27	13,5
	Axial	38,9				

Note: For complete encoder dimension please add connector and flange dimensions.

Shafts

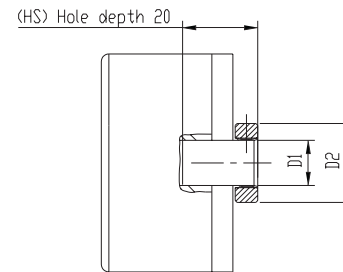

	D1	D2
ø8mm	ø8 G7	ø19
ø10mm	ø10 G7	ø19
ø12mm	ø12 G7	ø21
ø14mm	ø14 G7	ø23

Flanges

56

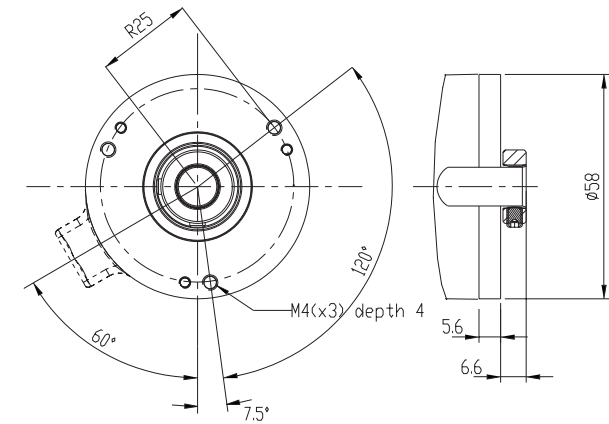

58

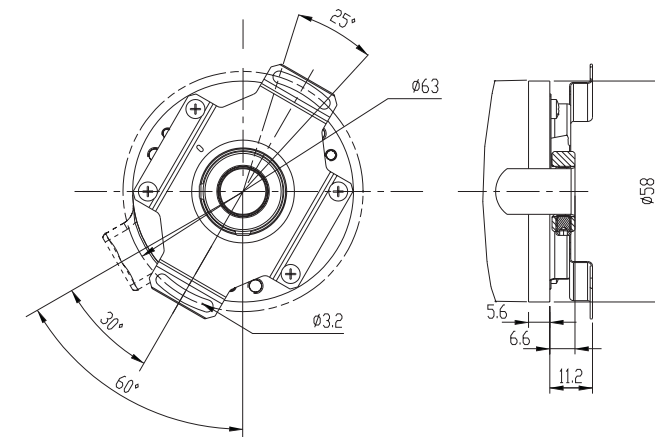

CANopen



Connectors

Cable
16x0,25 shielded

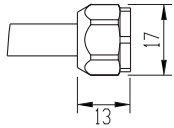

8pin M12

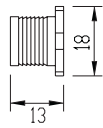

12pin EML

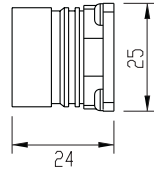

8pin PT

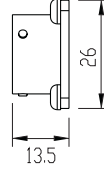

Various combinations/examples

RHA 507 56 12 mm , axial EML

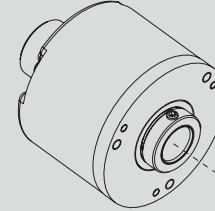

RHA 507 56 8 mm , radial cable

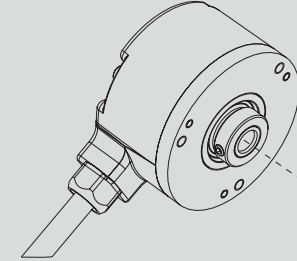

RHA 507 58 10 mm , radial EML

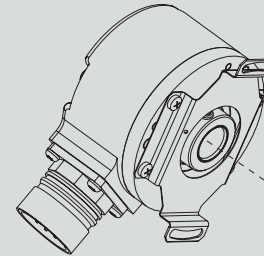

RHA 507 58 10 mm , radial cable

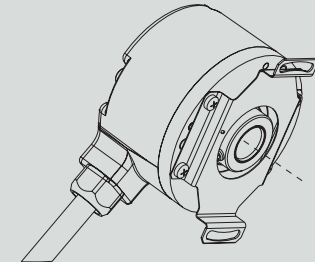

Ordering information Tick your choice

Type	RHA 507				
Flange	56, HS	58, HS			
Shaft	Ø8mm	Ø10mm	Ø12mm	Ø14mm	
Electronics	Supply	9-36Vdc			
	Output	SCO, CANopen			
Connection	Cable ⁽¹⁾	8 pin M12	12 pin EML	8 pin PT	
Connecting direction	Axial/Radial	Axial/Radial	Axial/Radial	Axial/Radial	
Resolution	13 bit				

⁽¹⁾ Note: Please specify cable length when ordering

Ordering example: RHA 507 56 ø10 9-36Vdc SCO 8 pin M12 Radial 13bit
Assembly drawing is available upon request from Leine & Linde AB