

# 607/608 — Ruggedized Hollow shaft encoder, Absolute

CANopen

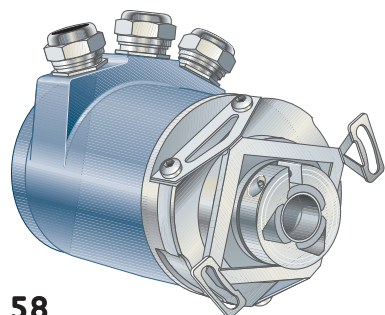

58

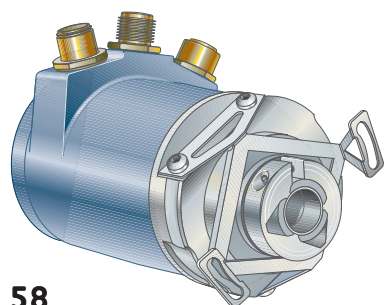

58

## Short description:

- >> CANopen output - DS 301 v4.02
- >> IP 67 at housing, IP 64 at shaft inlet
- >> Support encoder profile DSP 406 v3.1
- >> Robust enclosure for harsh environments
- >> Shock and vibration protected

## Suitable applications:

- >> Automation industry
- >> Packaging machines
- >> Cranes
- >> Elevators

## General information

Encoder data		
Operating temperature	-40°C .. +70°C	
Storage temperature	-30°C .. +70°C	
Ingress protection class	IP-67 according to IEC 60529	
At shaft inlet	IP-64 according to IEC 60529	
Vibration (55 to 2000Hz)	< 100 m/s <sup>2</sup> according to IEC 60068-2-6	
Shock (6ms)	< 1000 m/s <sup>2</sup> according to IEC 60068-2-27	
Cover material	Aluminium	
Weight	Approx. 400g	
Accuracy and resolution		
Encoder type	RHA 607	RHA 608
Total Resolution	13 Bit	25 Bit
Singleturn resolution	13 Bit	13 Bit (8192 absolute positions per revolution)
Multiturn resolution		12 Bit (4096 absolute number of revolutions)
Accuracy	± 1 LSB	

## Flange option

Flange type	58, HS
Type	Standard
Outer diameter	ø58 mm
Flange material	Aluminium
Torque support	Stator coupling

## Shaft option

Shaft type	Ø 12
Axial shaft load	10 N
Radial shaft load	20 N
Mech. permissible speed	6000 rpm
Shaft material	Stainless steel
Moment of inertia	4,3 x 10 <sup>-6</sup> kgm <sup>2</sup>



**CANopen**  
certified  
CiA200611-301V402/20-0067

**CANopen**

# 607/608 Ruggedized Hollow shaft encoder, Absolute

CANopen

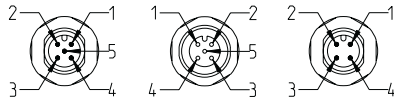

## Connection option

Connector type	Terminal Cable gland	5 pin M12 A-coded Male	5 pin M12 A-coded Female	4 pin M12 A-coded Male
Function	Marking	PIN	PIN	PIN
CAN Shield	NC	1	1	NC
CAN V+	NC	NC	NC	NC
CAN GND	G	3	3	NC
CAN_H	H	4	4	NC
CAN_L	L	5	5	NC
+E Volt	+	NC	NC	1
0 Volt	-	NC	NC	3
Connecting direction				
Radial	Yes	Yes		

NC=Not connected

## Electrical option

<b>Power supply</b>	<b>9-36Vdc</b>
Polarity protected	Yes
<b>Output interface</b>	<b>CANopen</b>
Supported profile	Encoder profile DSP 406 v3.1
Baud rate	Settable via switch, max. 1Mbit/s
Node address	Settable via DIP switches, 0...99
Zero-set function	Pushbutton or CANopen object
Code type	Binary
Supported functions	Code sequence, Preset, Velocity, Scaling, Acceleration, PDO mapping, Heartbeat and Node Guarding
Current consumption	90 mA @ 24Vdc
Max current consumpt.	150 mA @ 24Vdc

## Accessories

Configuration software	
CANopen	Part number
EDS file	588959-01
Cables and connectors	
CANopen connection	
Cable M12 5p M-F 5m, A-coded Straight	584409-01
Cable M12 5p M-O 5m, A-coded Straight	584412-01
Cable M12 5p F-O 5m, A-coded Straight	584417-01
Connector M12 5p M, A-coded Straight	586293-01
Connector M12 5p F, A-coded Straight	586299-01
Terminating resistor M12 5p M, A-coded Straight	586276-01
Supply connection	
Cable M12 4p F-O 5m, A-coded Straight	586238-01
Connector M12 4p F, A-coded Straight	586299-02

For additional accessories like torque support, torque arm etc. please advise separate datasheets for accessories.

## Ordering information

RHA 607	
577845-01	RHA 607 58 ø12hs 9-36Vdc SCO Cable Radial 13bit
577847-01	RHA 607 58 ø12hs 9-36Vdc SCO M12 Radial 13bit
RHA 608	
577848-01	RHA 608 58 ø12hs 9-36Vdc SCO Cable Radial 25bit
577850-01	RHA 608 58 ø12hs 9-36Vdc SCO M12 Radial 25bit

# 607/608

## Ruggedized Hollow shaft encoder, Absolute

CANopen



### Dimensions

#### RHA 607/608 58 ø12 cabel radial

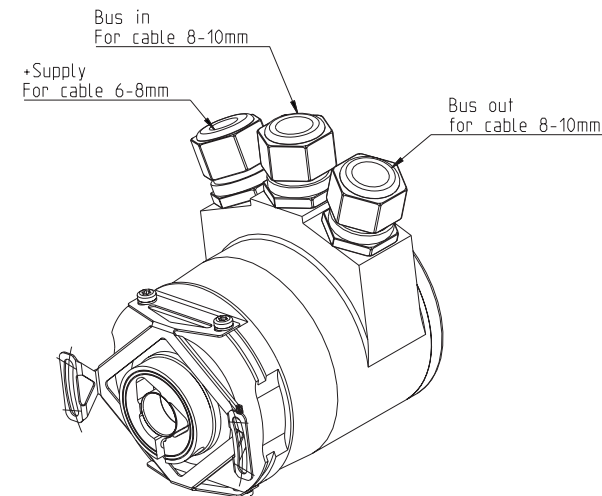
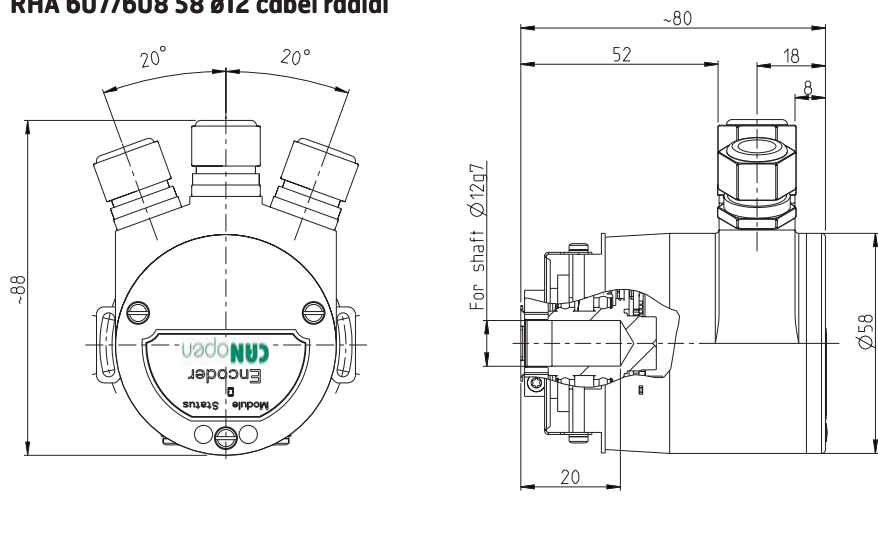

#### RHA 607/608 58 ø12 M12 radial

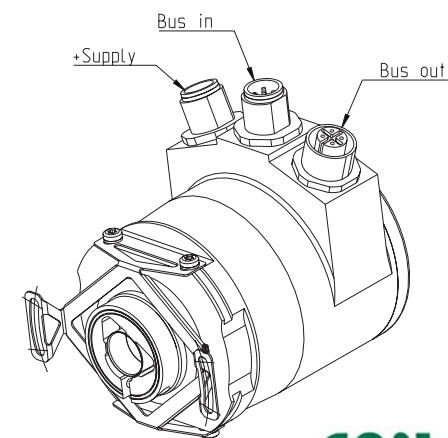
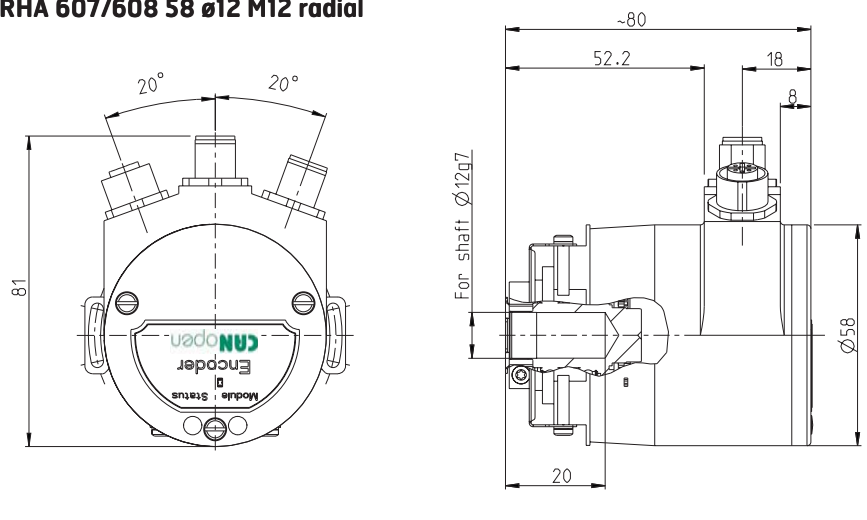

CANopen

# 607/608 — Ruggedized Hollow shaft encoder, Absolute

CANopen



**LEINE LINDE**

ISO 9001/ISO 14001 certified

Olivehällsvägen 8, SE-64542 Strängnäs, Sweden. Phone: +46 (0)152 26500. Fax: +46 (0)152 26505. E-mail: info@leinelinde.se

**CAN**open

[www.leinelinde.com](http://www.leinelinde.com)