

Heavy Duty incremental encoder

- ▶ High vibration and shock resistance according to IEC 68-2-6 and IEC 68-2-27
- ▶ Electrically insulated up to 2.5kV
- ▶ IP 66, encapsulation class according to IEC 60529
- ▶ 6 or 3 short-circuit protected outputs
- ▶ 9...30 Vdc, polarity protected power supply
- ▶ Available with Advanced internal diagnostics, ADS



ELECTRICAL SPECIFICATION

Supply voltage +EV	9-30V	
	Polarity protected	
Current consumption at no load	60mA @ 24V Max 80mA	
Line counts	500, 1000, 1024, 2048, 2500, 3072, 3600, 4096, 5000, 6350, 8192, 10000	
Measuring steps	4 x Line counts	
Accuracy	1-5000ppr	5001-10000ppr
Dividing error	± 50° el	± 90° el
Channel separation	90° ± 25° el	90° ± 45° el
Outputs	HC-HTL	HTL
	Short circuit protected	
Load max	± 40mA	± 40mA
Max cable length	350m @ 100kHz	200m @ 50kHz
U _{high} (at 40mA load)	> +EV - 4,0V	> +EV - 2,0V
U _{low} (at 40mA load)	< 2,5V	< 1,15V
Frequency range	0...100kHz	0...200kHz
Option	Advanced Diagnostic System ADS	
Alarm output	Opto-coupler	
OK	Closed-circuit	V _{CE} < 2V at 10mA
Error	Open-circuit	min 500ms
Voltage max	35V	
Current max	30mA	
PC communication	RS-232	Max 10m cable

ACCESSORIES

Torque arm	
M5	Part. No. 01208013
M6	Part. No. 01208014
ADS PC software kit	Part. No. 01209084

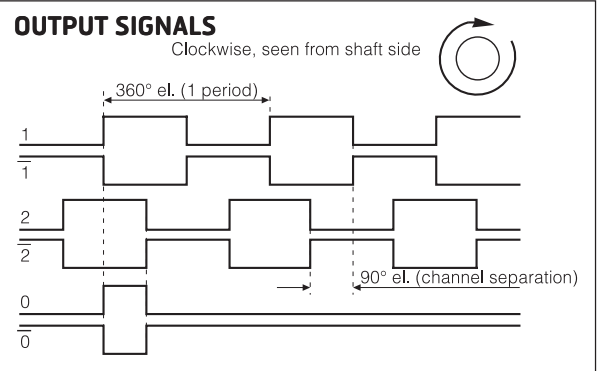
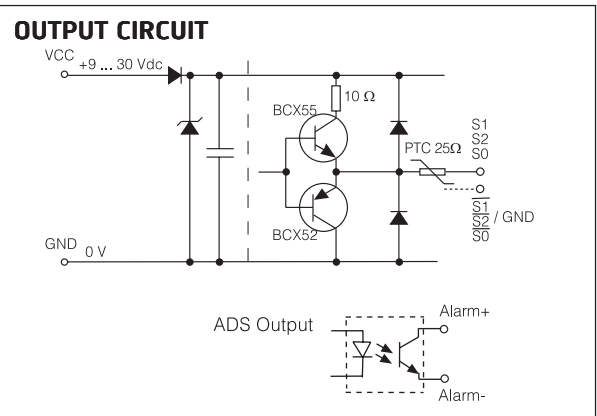

CONNECTION

Function	Terminal	12 pin EML	Colour
+ E Volt	1	12	Red
0 Volt	2	10	Blue
0	3	3	Brown
0 (0 Volt *)	4	4	Violet
1	5	8	Green
1 (0 Volt *)	6	1	White
2	7	5	Yellow
2 (0 Volt *)	8	6	Black
Alarm +	9	9	Grey
Alarm -	10	11	Pink
RXD	11	7	Grey / Pink
TXD	12	2	Red / Blue
Case			Shield

* 3 channel output. All 0 Volt pins are internally connected on the PCB.

ADS outputs

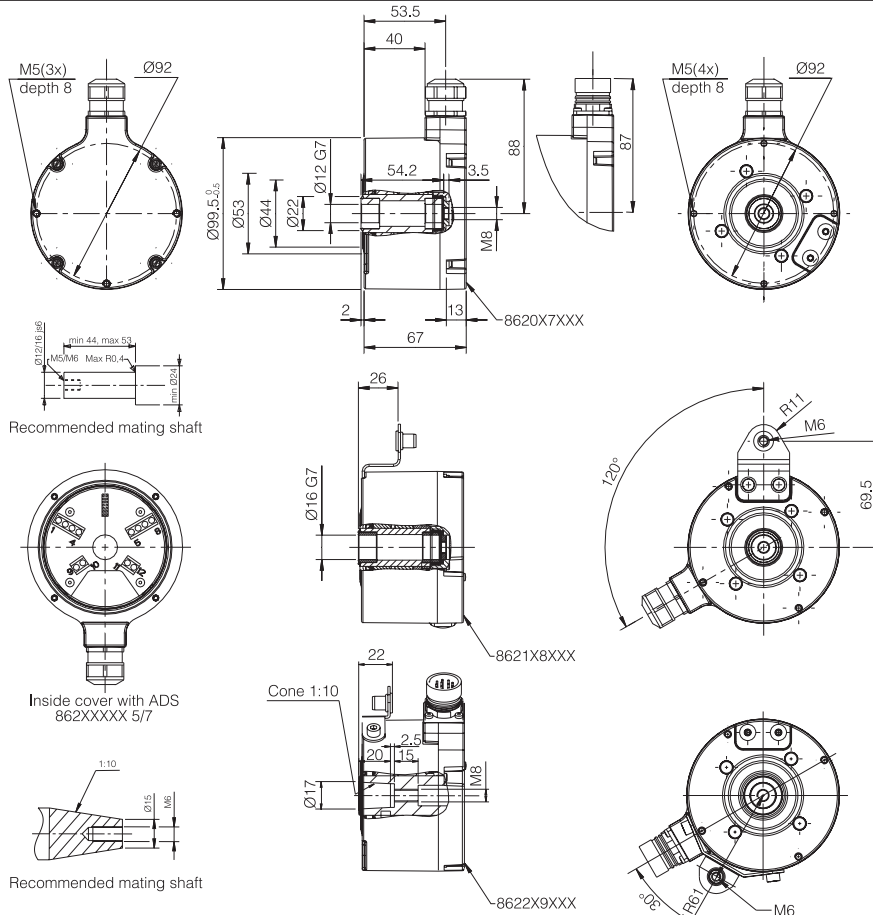

MECHANICAL SPECIFICATION

Isolated Hollow-shaft	Ø12, 16mm, Stainless steel	
Moment of inertia	55 x 10 ⁻⁶ kgm ²	
Load max		
Radial	300N	
Axial	100N	
Speed max	4000 rpm	
Code disc	Extended temp	
Temperature		
Operating	High current HTL -40°C ... +80°C	HTL -40°C ... +100°C
Storage	-40°C ... +80°C	-40°C ... +100°C
Housing	Aluminum, coated	
Weight	Approx. 1300g	
Protection class	IP 66 according to IEC 60529	
Electrical isolation	<2.5kV	
Vibration	<100m/s ² (50...2000 Hz) IEC 68-2-6	
Shock	<1000m/s ² (11ms) IEC 68-2-27	
Cable	10x0,25mm ² twisted pair PVC (Not ADS)	
Connector	12 pin EML	

ORDERING INFORMATION

8 6 2 - 0 - - - - -

Option

Mechanical

- 0 = Standard
- 1 = 120° torque bracket
- 2 = 30° torque bracket

Hollow-shaft

- 7 = Ø 12 mm, insulated up to 2.5kV
- 8 = Ø 16 mm, insulated up to 2.5kV
- 9 = Ø 17 mm, taper shaft, insulated up to 2.5kV

Connection

- 1 = Connector, radial 12 pin EML CW
- 2 = Connector, radial 12 pin EML CCW
- 3 = Cable, radial 1.5 m
- 4 = M20 cable gland, radial Ø8-11mm
- 5 = M20 cable gland, radial Ø11-14mm
- 9 = Cable, radial xx m

Supply voltage

- 2 = 9..30 Vdc (HC-HTL), overvoltage protected
- 3 = 9..30 Vdc (HTL), overvoltage protected
- 5 = 9..30 Vdc (HC- HTL)
- 6 = 9..30 Vdc (HTL)

Outputs

- 4 = 3 channels 1, 2, 0*
- 5 = 3 channels 1, 2, 0 with ADS**
- 6 = 6 channels 1, 1, 2, 0, 0
- 7 = 6 channels 1, 1, 2, 2, 0, 0 with ADS*

Line counts

- 500, 1000, 1024, 2048, 2500, 3072, 3600, 4096, 5000
- 6350, 8192, 10000 ppr (Other line counts on request)

* Not available with supply voltage option -3- or -6-

** Not available with supply voltage option -3- or -6- or EML connector